

A Review Paper on Modeling, Generations and MPPT Techniques of Solar PV System

¹Mr. Mohd Amir, ²Mr. Mohd Yasir, ³Mr. Himanshu Bhushan, ⁴Dr. Sachin Singh

^{1,2}UG Student, Department of Electrical Engineering, SRMGPC, Lucknow, Uttar Pradesh, India

^{3,4} Assistant Professor, Department of Electrical Engineering, SRMGPC, Lucknow, Uttar Pradesh, India

Article Info

Volume 82

Page Number: 15743 - 15749

Publication Issue:

January-February 2020

Abstract:

Today the rate of depletion of conventional resources is at a very rapid pace. So, there is a need to shift the attention to the alternative resources of energy out of which solar energy is owed. Solar energy is the radiant light and a heat from the sun that is harnessed using a range of ever-evolving technologies like solar heating, photovoltaic, etc. In this paper, the modeling of the photovoltaic cells along with their characteristics and circuit diagram is illustrated. And different existing maximum power point tracking techniques have been analyzed and compared.

Article History

Article Received: 18 May 2019

Revised: 14 July 2019

Accepted: 22 December 2019

Publication: 28 February 2020

Keywords: PV Generations, Solar Cell, MPPT Techniques, Photo current, Genetic Algorithm.

I INTRODUCTION

The ultimate source of energy is "sun". The sun is crucial part of solar system, which is burning over 4000 million years. According to a study, the quantity of energy that the earth has been receiving from the sun. the amount of energy, that the sun has been providing is somewhat less than or equal to energy available at all the resources. In the field of solar generating electricity, the first invention was done by Swiss scientist; "Horcedesaussure" was solar thermal collector [1].

The second invention was done by a French scientist, "Alexander Edmond" in the year 1839, was delivering electrical form of energy from solar energy. This was the first step into the field of solar cell technology. In this paper we are going to throw light upon the generation of photovoltaic cells in 21st century. Basically, till date there is 3 generation of PV-cells [2].

- The 1st generation has solar cells, which has higher cost to install and low efficiency to have.
- The 3rd generation that have high efficiency and can be used commercially [3].

- The 2nd generation, although have lower efficiency, but their cost of manufacturing and installation is also low, comparatively to 1st generation.

Inverters are the most crucial part of a solar energy system connected to a grid. This is a power electronic converter that basically changes the DC output, available at PV to an alternating cycle required at the load. Based upon their architecture and designing there are basically three kinds of inverters, namely:-

- Centralized inverters, which is likely to use for large scale integration and has a common and single MPPT for each panel of an PV array
- String inverters, in which basically all the panels are connected to model a string and then a common inverter is link to that string.
- Module integrated micro inverter, where every PV module has their particular inverters, which are having their own MPPT.

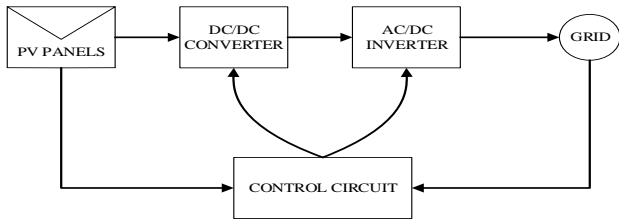

Fig 1: Block Representation of Grid Connected PV System

PV panel installed here produces a DC output which is fed to a DC-DC boost converter. The main function of this converter is to increase the magnitude of dc voltage, then supply this voltage to the inverter. Here the DC voltage is converted into an Ac voltage and then it is supplied to the 3- phase or a 1-phase grid. Control circuitry is also provided whose main operation is to provide the control signals to the converter and the inverter as demanded by the grid. Maximum power point is also included the system whose main function is to track the maximum point I order to maximize the energy harvesting using various control techniques.

II MATHEMATICAL MODELING OF PV CELL

The equivalent circuit diagram of PV cell is shown below where I_{ph} represent photocurrent and R_{sh} , R_{se} are shunt and series resistance of the cell.

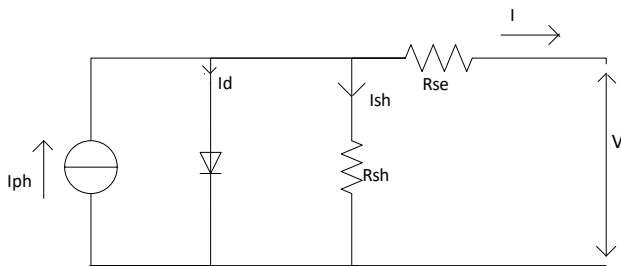

Fig 2: circuit diagram of PV Cell

From circuit diagram,

$$I_{ph} = I_d + I_{sh} + I$$

(1)

Here I_{ph} is photocurrent, I_d is the current going to diode and I_{sh} is the shunt current of the cell. Cell shunt current (I_{sh}) is given as

$$I_{sh} = \frac{(V + I_{Rs})}{R_{sh}} \quad (2)$$

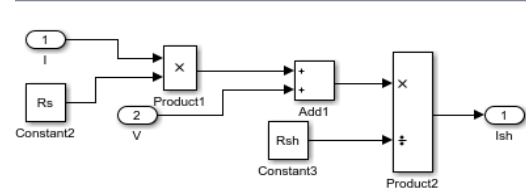

Fig 3: Modeling of shunt current

Saturation current I_o :- By p-n junction theory saturation current is given as

$$I_o = I_{rs} * \left[\frac{T}{T_n} \right]^3 * e \left[q * E_{go} * \left[\frac{\left[\frac{1}{T_n} \right] - \left[\frac{1}{T} \right]}{n * K} \right] \right]$$

(3)

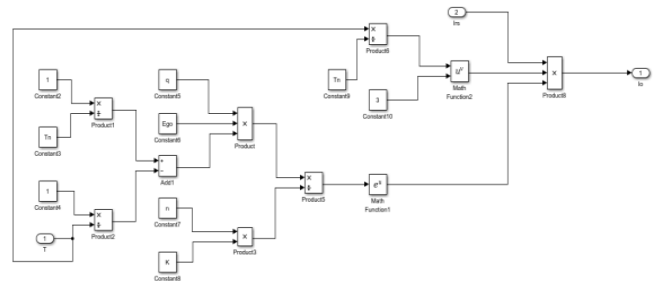

Fig 4: Modeling of saturation current

Here I_o is the reverse saturation current, n is the ideality factor of the cell, I_{rs} is reverse saturation current, T_{is} the operating temperature, T_n is nominal temperature, q is the electron charge, E_{go} is the band gap energy of the semi conductor, K is the Boltzmann constant.

Reverse saturation current:-

$$I_{rs} = \frac{I_{sc}}{\left(e^{\left(\frac{q * Voc}{n * K * T} \right)} - 1 \right)} \quad (4)$$

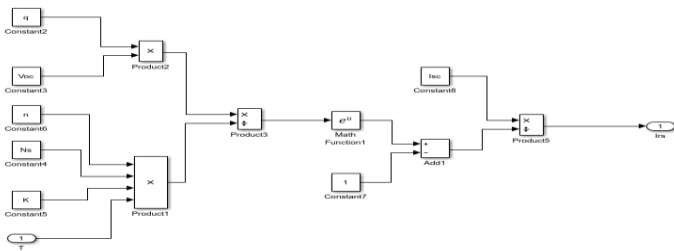

Fig 5: Modeling of reverse saturation current

Cell photocurrent is given as

$$I_{ph} = \left[I_d + K_i (T + 298) \right] \left(\frac{G}{1000} \right)$$

(5)

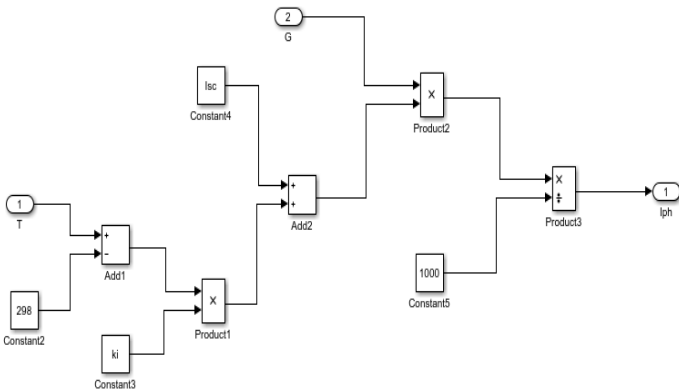

Fig 6: Modeling of photo current

Here G is the solar irradiant, T is the operating temperature, K_i is short circuit current of the cell at 25°C and $1000\text{W}/\text{m}^2$. The output current of the cell is given as

$$I = I_{ph} - I_o \left[e^{\left(\frac{q(V + I * R_{se})}{N * K * T} \right)} - 1 \right] - I_{sh}$$

(6)

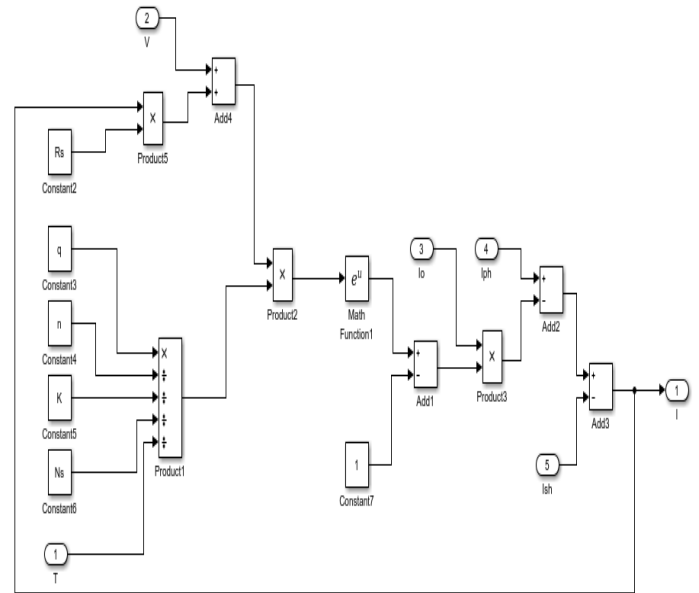

Fig 7: Modeling for output current

Now we have to give the values of constant as given in the table also we have to connect all the input to the output current

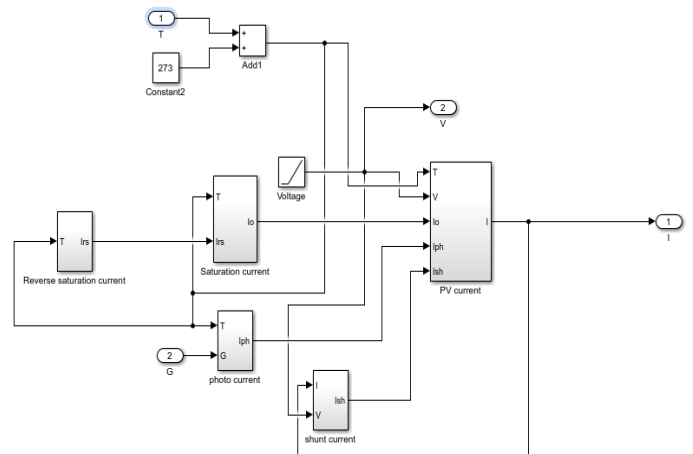
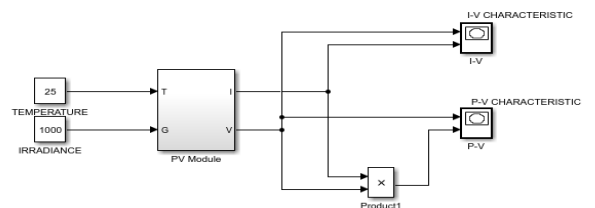

Fig 8: Modeling of characteristics equation

A. V-I and P-V CHARACTERISTIC



I-V characteristic:

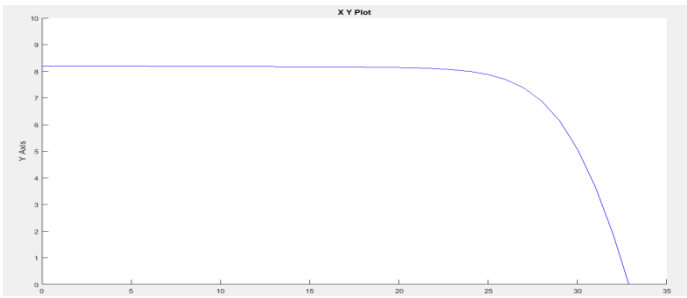

Fig 9: I-V Characteristic of PV Cell

P-V characteristic:

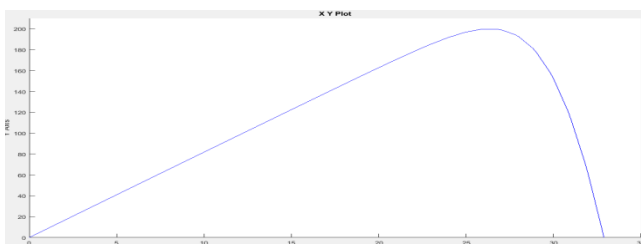

Fig 10: P-V Characteristic of PV Cell

III GENERATION OF PV CELL

A. FIRST GENERATION SOLAR CELL

In this PV-cells are categorized into three kinds, based on their materials-

- a) Crystalline silicon
- b) Thin film
- c) Concentrated PV and organic material.

PV-cell made up of crystalline silicon which is a wafer based material. The major reason behind this is that crystalline silicon is the technology which is capable of reducing the cost by modifying the manufacturing process and material. Its manufacturing and production started in the year 1963 [4].

B. SECOND GENERATION PV CELL

They are consisting of thin light successive films of solar cells, concentrated over a substrate[5][6]. The substrate maybe glass, polymer. These second generation of PV-cells have problem that they provide low cost electricity as compare to previous generation [7]. Basically, the three major types of second generation thin films solar cells are:-

- Amorphous Silicon (a-Si)

- Cadmium Telluride (CdTe).
- Copper-Indium Selenide (Cis).

The efficiency of second generation is less than the first generation as well as their capital cost is also less than that of first generation[8]. There are no finger present on the thin film solar cells for the purpose of metallization, because of this fact they can easily be installed on windows, cars etc. Also, they can be extended up to an area of $6m^2$

*Amorphous Silicon:-*They are widely used and well known solar cells. Because of its fashionable and demand in the market the various companies started developing Amorphous Silicon modules for flat and curved surfaces as per the consumers need. They are lesser in rate because they are deposited on cheap and a very large substrate (like glass).

*Cadmium Telluride:-*These are combination of two materials namely telluride and cadmium [9]. It assumes the efficiency of about 16percent to 18 percent. Although it is cheaper than silicon in terms of cost but has less efficiency comparatively to silicon .

*Copper-Indium Selenide:-*This type of solar cell has commercial production. The efficiency of this type of cell is about 8 percent but in the laboratory it has been up to 20.3 percent [10]. On the other hand the CIGS type of solar cell has its own benefit.

- Low static loads.
- Ability to absorb direct and indirect sunlight.

Because of all these advantages and benefits, the CIGS type of solar cell can be used on flat roof and in winters .Also CIGS has annual production of about 1GW capacity.

C. THIRD GENERATION SOLAR CELL

The cells in this generation are at commercial stage. It varies from new technologies to established technology and still under the research operation. Basically, basically there are four different kind of 3rd generation PV-Cell.

- CPV (Concentrating PV-Cell)

- Dye-sensitized
- Cooling of CPV system.
- Organic solar cells[11].

Among all the four 3rd generation solar cells, the mostly developed and mature are CPV and dye-sensitize PV-Cell.

IV. MPPT TECHNIQUE

A. Perturb And Observe

This consists of a booster converter that boosts the magnitude of a voltage along with a digital controller, working on a P&O Algorithm. The result obtained from this shows that with the reduction in a oscillation curve the maximum power can be obtained. But there are some restrictions to this method as well like inability to locate the maximum peak during the partial shading condition, divergence from the solar radiation tracking[12].

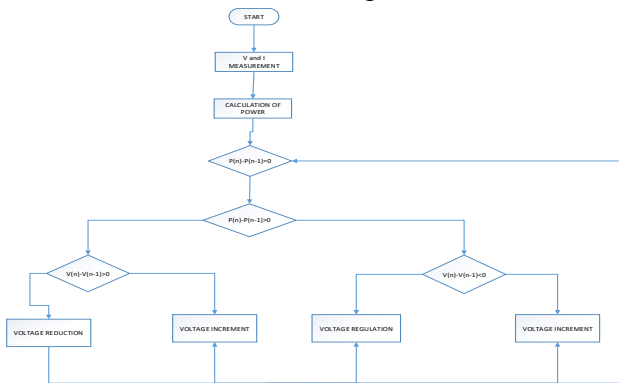

Fig 11: flow chart of perturb and observe method

B. Modified Perturb and Observe

This is the uplifted and developed method of the above P&O technique in which the climatic conditions are taken into considerations. An improved MPPT Algorithm that can even operate under unwanted and unfavorable conditions (that directly or indirectly affects the overall performance of the system) are presented under this category.

C. Artificial Neural Network

The ANN tracker is one that continuously tracks the voltage and the current that are required to achieve maximum power by solar PV cell under different temperatures and radiations. The algorithm

used in this method is back propagation algorithm. Generally, this tracker is employed to cover the sets of almost 124 arrangements of Cell[13]. By integrating various test cases and the data, this technology can be improved further more [14].

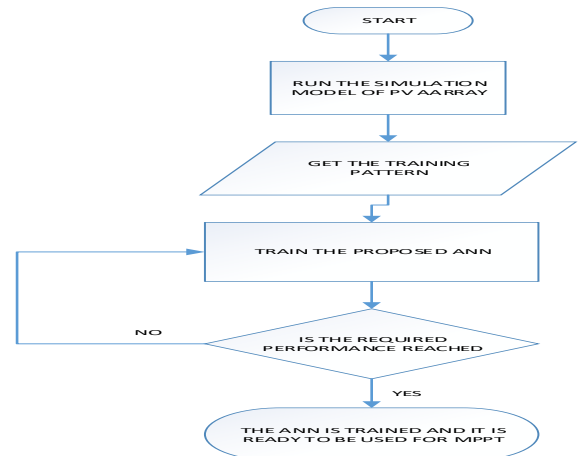

Fig 11: flow chart of artificial neural method

D. Fuzzy Logic Algorithm

In this, the fuzzy logic control is used to obtain the peak of raised current [15]. In this algorithm P&O type algorithm is modified to reduce the drawbacks of the conventional P&O algorithm and raise its overall performance to operate even in the unwanted climatic conditions and variations [16].

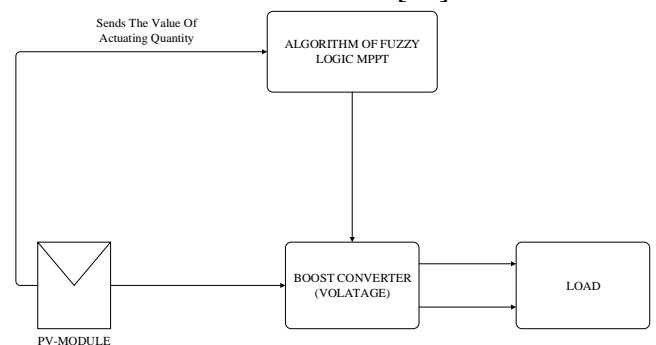

Fig 11: flow chart of fuzzy logic method

E. Genetic Algorithm

In a genetic algorithm based MPPT the various resistive, inductive reactive and various non linear loads are switched at variable time and instants in parallel with the varying solar temperature and

radiations[17].Perhaps it is one of the most pre owned techniques in PV system.

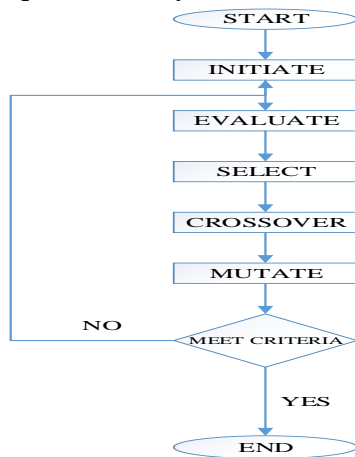

Fig 11: flow chart of genetic algorithm method

F. Particle Swarm Optimization

This method is beneficial in reducing the steady state fluctuations when the MPP is tracked [18]. In addition to this, during partial shading and the large changes in the irradiance and temperature the method is sufficient enough to track the MPP.

CONCLUSION

The primary aim of this work is to provide more insight about the various techniques of MPPT algorithm along with the various generations of PV Cell. It also discusses the mathematical modeling of photo-voltaic systems. Working of different maximum power point techniques are elaborated along with their advantages and limitations.

REFERENCES

1. Solar cell current scenario and future trends by Recent Research in Science and Technology 2012, 4(8): 99-101, ISSN: 2076-5061.
2. Solar Cell Research Activities at Plasma & Material Processing group-Adriana Creatore, Richard van de Sanden and Erwin Kessels Jurgen Palmans, Ilker Dogan, Samir Hanssen, Sjoerd Smit, Bas van de Loo, Bart Macco Stefan Bordihn, Harm Knoops, Diana Garcia-Alonso, Kashish Sharma, Technische Universiteit Eindhoven- University of Technology.
3. Green, M. A, " Clean Energy from Photovoltaics ", World Scientific Publishing Co., Hackensack,

- NJ, 2001.
4. Review on Photovoltaic Solar Energy Technology and its Efficiency Department of Electrical Engineering University of Alexandria Alexandria, Egypt.
5. Dena German Energy Agency, "Information about German renewable energy, industries, companies and product(Federal Ministry of Economics and Technology)", pp. 41, 2013-2014, ISIN: B002MNZE4U.
6. Review on Photovoltaic Solar Energy Technology and its Efficiency Department of Electrical Engineering University of Alexandria Alexandria, Egypt.
7. K. L. Chopra, P . D. Paulson, and V. Dutta," Thin - film solar cell overview", Prog. Photovoltaic: Res.,vol. 12, , 2004, pp. 69-92.
8. Review on Photovoltaic Solar Energy Technology and its Efficiency Department of Electrical Engineering University of Alexandria Alexandria, Egypt.
9. Dena German Energy Agency, "Information about German renewable energy, industries, companies and product(Federal Ministry of Economics and Technology)", pp. 41, 2013-2014, ISIN: B002MNZE4U.
10. Green, M.A. et al, " Solar Cell Efficiency Tables progress in Photovoltaics:Research and Applications", Vol. 19,2011, pp 84-92.
11. Nicole Foureaux, Alysson Machado, Érico Silva, Igor Pires³, José Brito and Braz Cardoso F, "Central inverter Topology Issues in Large-Scale Photovoltaic Power Plants: Shading and System Losses", IEEE Photovoltaic Specialist Conference (PVSC), pp.1-6, June 2015.
12. Q.Li and P. Wolfs, "A Review of the Single Phase Photovoltaic Module Integrated Converter Topologies With Three Different DC Link Configurations," IEEE Trans. On Power electron. vol. 23, pp. 1320-1333, May 2008.
13. Dr. Mike Meinhardt and Gunter Cramer, "Past, present and Future of grid connected photovoltaic and hybrid power systems" IEEE Power Engineering Society Summer Meeting, vol. 2, pp.1283-1288, 2000.
14. Soham Deshpande, N . R .Bhasme. "A review of topologies of inverter for grid connected pv systems", 2017 Innovation in Power and

- Advanced Computing Technologies (i-PACT), 2017.
15. Nimita A. Gujjar, Tejas N. Zaveri. "A Review of DSTATCOM Used in Solar Photovoltaic System", 2018 International Conference and Utility Exhibition on Green Energy for Sustainable Development (ICUE), 2018.
 16. M.R.Rezoug, R.Chenni and D.Taibi, "Fuzzy logic based perturb and observe algorithm with variable step of a reference voltage for solar permanent magnet synchronous motor drive system fed by direct-connected photovoltaic array," *Energies Journal*, Elsevier, Vol. 11, No. 462, pp. 3-15, 2018.
 17. N. E. Zakzouk, et al., "Improved performance low-cost incremental conductance PV MPPT technique," *IET Renewable Power Generation*, pp. 1-14, 2015.
 18. R. I. Putri, S. Wibowo and M. Rifa, "Maximum power point tracking for photovoltaic using incremental conductance method," 2nd International Conference on Sustainable Energy Engineering and Application, *Energy Procedia*, Elsevier, Vol. 68, pp. 22-30, 2015.