

Smart Trash Bin

NithyaPriya.S¹, Kannaki.², Emmanuel Gospel Raj.R³, Ananthi.k⁴, Indirapriyadharshini⁵
^{1,2,3,4,5}Assistant Professor, Sri Krishna College of Engineering and Technology, Coimbatore, India.
¹nithyapriya@skcet.ac.in, ²kannakis@skcet.ac.in, ³emmanuelgospelraj@skcet.ac.in,
⁴ananthik@skcet.ac.in, ⁵indirapriyadharshini@skcet.ac.in, aishwaryalakshmik@skcet.ac.in

Article Info**Volume 82****Page Number: 14088 - 14095****Publication Issue:****January-February 2020****Article History****Article Received: 18 May 2019****Revised: 14 July 2019****Accepted: 22 December 2019****Publication: 26 February 2020****Abstract**

The technology, method, or system that governs or controls a process through highly automated means, as done by electronic devices, reduces human interference known as automation. For example vegetable slicing is a time consuming task in our busy schedule. In this project, development of a Smart bin the tin cans and plastic bottles might crush as flat with low cost. Environmental friendly designs are made with the use of simple mechanism properties. This project helps to easily manage waste in Railway stations, malls etc.

Keywords: Cans and bottles, Crushing, Presser, Automation, Design & development

I. INTRODUCTION

India is a narrow country made up of several states with a population of over 1.252 billion. Due to the high density of the population, there are not many places for landfill infrastructure. 80% of solid waste materials in India are treated in thermal treatment plants to save land treatment space. There are around 2000 incinerators described in the world. Thermal treatment, 40% of them are located in India. After the 1960s, large-scale production, and large-scale distribution, consumption and disposal are the reasons for high economic growth. Before 1975, to treat solid wastes municipalities chose landfill as their solution. To address solid waste, a number of thermal treatment plants installations have been established in India since 1975, causing large amounts of dioxin to be produced each year. Recycled Plastics (Construction and Use) Rules, 1999. In exercise of the powers conferred by clause (viii) of sub-section (2) of Section 3 read with Section 25 of the Environment (Protection) Act. In 1986, the Central Government laid down the principles for the production and use of recycled plastic bands and containers. "Staples" refers to the nutrition of liquids, powders, nutrition and nutrition products in a strong or semi-structured, inexpensive food, maintained and prepared. "Merchant" refers to

a grocery seller, packing specialties and placing them in plastic packs and containers

Experts recommend establishing these principles identified with the Pollution Control Committees on production and recycling, the State Pollution Control Council and the States and Union Territories. The district collector / deputy commissioner of the relevant government, authorized to authorize the setting of these guidelines identified with the use, classification, isolation, transit and transfer, is not authorized by the State Government / UT. Under any law relating to non-biodegradable waste. Restrictions on the use of plastic packs or reusable plastic containers. No merchant should be used to make plastic, used bins, fuzzi or grocery baskets.

Plastic Bags or containers can be manufactured by anyone, especially if the conditions are fulfilled: packs and containers made of Virgin Plastics with simple shade or white coloured bags and reusable. Holders made of plastic can be used for other purpose putting away and bundling staples will be fabricated utilizing colors colorants according to IS 9833: 1981 "Shades and Dies Rounddown for Plastic Use in Grocery and Drinking Water". Crushers are made up of steel, it can be defines as A can crusher can be defined as "to press or squeeze

with a force that destroys or deforms an aluminium cans for achieving 65% volume reduction [5]. Most of the food items are canned in today's life, which can be placed in any public areas like restaurants, park, mall, theatre, etc. The volume of aluminium cans can be reduced to 80% by can crushing machine design is described [1], The empty aluminium can be smashed into a smallest unit by a can crusher. The can crusher is very much needed in recycling plants and people gathered area. While fulfilling recycling duty, the aluminium waste can be reduced in a easy way by can crusher which is most efficient, convenient and space saving. Crush the can and save the space, time and energy. The earth will thank you.[2].

Recycling is an excellent way to start the land, and you usually think about it when you are pulling huge, large bastards filled with empty bins for control. Crusher is a gadget that simplifies our lives, and makes our reuse more conventional. The Crusher can be accessed in a variety of styles, sizes and speeds, from heavy soft drinks user to reusable Focus Director. In this venture, we have created a physically functional crusher that can conceive at the level of the tin and uniform before reaching the bin. The structure uses the neighboring position and basic procedures. [3]

When people grind the tin after completing their drink, the tin does not look consistently the same and it looks pale. At some point this condition produces tin, which can cause sharp maximum damage or damage to people. Additionally, individuals constantly throw cans and plastic bottles anywhere. These conditions can cause contamination of the condition, which becomes awkward and breaks the trench. Therefore, the scheme is used to suppress crates and plastic bottles, and at that time, the cost, cost and effort of the sharp edge is expected along with the expected size of the Howell Crusher.

II. METHODOLOGY

A. Selection of Mechanical components

Frame (Chassis)

Work piece is placed and machined in the frame stand or the work table. The base support for the machine is a frame stand. In this machine, the whole body of the machine is supported by frame stand.

The steel used in the construction of the chassis is a lightweight steel grade E618 - 07 (2013).

E618 - 07 (2013) Standardized Test Method for Evaluation of Matching

Performance of ferrous metal using automatic

The screw / bar can stand with the machine and heavy load

Pneumatic cylinder

For sequential or repetitive operations, the replacement of manual effort by mechanization is known as Mechanization. The compressed air system is used in many plants and factories for proving power requirement and the control system (Equally important is the fact that pneumatic control systems are economical and can be utilized in other forms of energy). Due to simplicity maintenance cost is low in pneumatic system which a main advantage of using pneumatic system. The another outstanding advantage in pneumatic system is its safety.

Pneumatic cylinder double acting cylinder used to generate power for crushing



Figure 1: Pneumatic Double acting cylinder.

The power source for crushing is provided by the compressor, which is capable of producing up to 6 bar pressure.

Flow control valve

Solenoid Operated

In hydraulic industry it is widely used. Electromechanical solenoids are used in these valves for sliding of the spool. These valves are used extensively because of its control which is provided by electrical power. Large amount of electrical power is needed for electrical solenoid to generate a large force. Heat production is a great threat to the widespread use of these valves when activated over time. The duty cycle is limited to these types of valves. For these reasons they are commonly used in less active energies.

Low-power solenoid valves are often used to operate a small hydraulic valve (called a pilot), which initiates current flow on a large hydraulic valve that requires more power.

The bi-stable pneumatic valve is usually a pilot valve, a 3 port 2 position detection valve.

Bi-stability can be achieved with a coil of polarity sensitive with mechanical detective and 2 contrasting solenoids or "magna-latch" magnetic latch. Positive opens and negative closes or vice versa. When activated the coil is kept in the magnetic position.

Solenoid valve:

The directional valve is an important part of the pneumatic system. The direction of airflow in the pneumatic system is controlled by directional valves that change the location of its internal moving parts., which is commonly referred as DCV.

Solenoid valves are selected to reduce manual effort and turn the machine into an automatic machine for quick operation. Using the solenoid, the electrical energy is converted into a straight line motion and energy. Solenoids can be push type or pull type. When solenoid is energized electrically, the plunger is pushed in a push type solenoid. When solenoid is energized, the plunger is pulled, which is pull type solenoid.

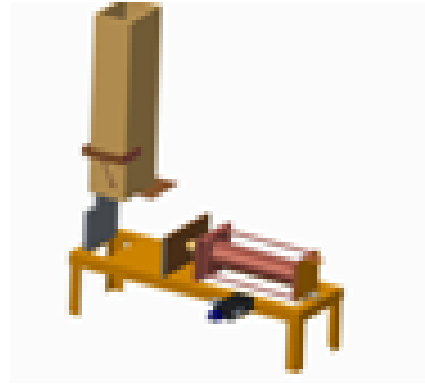

Figure2: Conceptual Design

PU connections, Reducer and Hose collar

Two types of connectors are used in our pneumatic system. They are hose connectors and reducers. The hose connectors include the adapter hose nipple and the cap nut. Hose connectors are made of brass or aluminum or hardened steel.

Two pipes or hoses of different sizes are interconnected by using a Reducers. It may be fitted in the form of tee, straight, V configurations. The polyurethane pneumatic hoses are used. The maximum pressure level of the hoses is 10 kg/cm².

The tubes used in this pneumatic system are made of polyurethane. These hoses can stand up to a maximum pressure of 10 kg / cm².

B. Selection of electrical components

Control unit

One or more electrical system or subsystem in a motor vehicle are controlled by embedded system is termed as Electronic Control Unit (ECU). 80 ECUs are used in some modern motor vehicles. Embedded software line count, complexity and sophistication in ECUs continues to increase. Maintaining the increasing complexity and number of ECUs in the vehicle is a major challenge for manufacturers of original equipment.

In this paper, to activate and deactivate the vehicle braking system, the control unit is used for controlling the DC motor due to its simple operation. The control unit turns on the motor when the brake lock system is activated from the remote.

When the brake lock system is deactivated from the remote the motor direction is reversed by the control unit.

Control timer circuit

The solenoid valve can be activated over a period of time with the help of a timer circuit to achieve the optimal linearity at the desired level.

Electronic control timing unit:

The multivibrator uses a 555 IC. The output of IC 555 is fed to the input pin (pin number 14) of CD4017. Pins 2,3,4 Output Pins. When the output pulse trigger (placed) of one of the output pins is traced the current flows across the load. This process continues at different time intervals for the other pins and the cycle continues. By adjusting the pre-set form associated with pin 6 of the 555 Timer IC, the cycle frequency interval (time) is varied.

IC 555 TIMERS

For producing accurate time delay and oscillations, the IC SE / NE 555 monolithic circuit is used which is a stable controller. For triggering and resetting operations, additional terminals are provided in a controller. By using one external resistor and capacitor time is precisely controlled in a timing operation. Free running frequency environments and duty cycles can certainly serve as an oscillator with external RC constants.

The important features of IC555 are,

From microsecond to time.

Both static and mono stable operation are possible.

The duty cycle can be adjusted based on need.

It is capable of operating over a wide range of supply voltages.

Controller

The Raspberry Pi Foundation is a mastercard-projected single-board PC breakthrough in the United Kingdom to further enhance software

engineering education in schools and developing countries.



Figure 3: Raspberry Pi

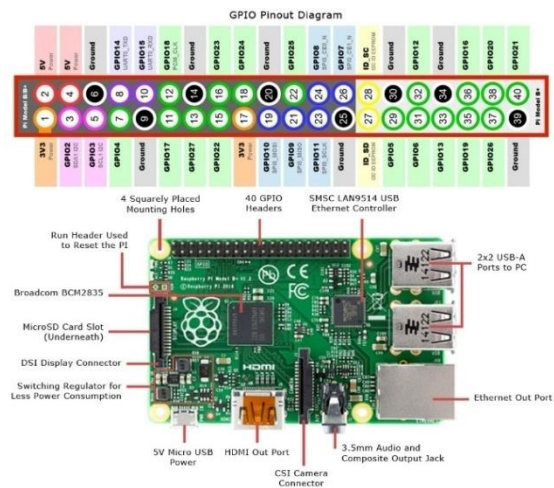

Figure 4: Raspberry Pi Pin configuration

Advantages of Raspberry Pi

Pi is an essentially a smaller than expected PC, I chose to take it for a turn and see what I could toss at it, and I have been charmingly astounded. Truth be told, it's been effective to such an extent that I've chosen to take a stab at setting it up as a smaller than normal server with different administrations. In doing as such, I've thought of a rundown of focal points that I feel are extremely convincing.

Power consumption - It draws five to seven watts of energy. This is about a tenth of what a practically identical full-size box can use. Since servers are running constantly at night and day, electricity investment funds can actually participate. If left to run 24x7x365, I have decided that the original P pack (pie board, case and power supply) will pay for itself out of one year's power investment funds. I wound up with the Ken Kit Basic Kit (ASIN #

B00DG9D6IK), which is really medium and of great quality.

No moving parts - The Pi uses an SD card for efficiency, which is quick and has no moving parts. Additionally no fan and there are different things to stress. The Class 10 SD card usually performs best with a lower class card, although it can affect boot time where there is a lot of I / O. Here is the similarity graph for the SD card, the results are still fluctuating and the bigger one I have had the better luck with the transdesce card which gives good value.

No noise - The Pi is totally quiet.

Status lights - There are some status lights on Pi's motherboard. With the right case you can see the action of NIC, Plate I / O, Power Status and so on.

Expansion capabilities - There are a variety of devices available at the Pi, at a moderate cost. Everything from I / O board (GPIO) to camera. There are two USB ports on the top; Therefore, more devices can be added by adding a controlled USB center point.

Built in HDMI capable graphics - The display port on the Pi is HDMI and can handle resolutions up to 1920 × 1200, for example, making the pi in the video player box. There are some converters that can be converted to VGA for reverse parity. The reduction from HDMI to VGA converters can be seen here. I have worked wonderfully up to this point using VGA Link (ASIN # B0088K7QUQ) from Saxony HDMI.

Affordable -Unlike many other comparable options, the Pi (Revision B) offers the best specs at any rate, which I have found. It is one of the few devices in its group to provide 512 MB of RAM. As shown above, the above costs have been reduced and leisure activities, business use or necessity are long justified.

Huge community support - There is exceptional network support. Support for tools or potential GNU / Linux programming can be efficient, which can

suddenly increase the demand for Pi in customer discussions, perpetuating the use of the GNU / Linux allocation. Good land of ruins can be found here.

Over clocking capability - If there is an execution problem with the application used, the above can be terminated, however the client is at risk of doing so.

Multiple uses - Having the SD card enabled makes it easy to swap out other SD cards running the GNU / Linux campaign and quickly and efficiently change the purpose of Pi. You don't need to install the above to run it as a server to test it, then move the knife to another, change the SD card, and you're done. By using the "dd" command on the GNU / Linux PC, reinforcements of the SD card can be made and reinstalled later if necessary.

Raspberry pi camera module

The Raspberry Pi Camera Module is useful for capturing top videos such as still photos. It is difficult to use for anything but teasers, however there is a gift to offer to potential customers if you hope to increase your insight. There are loads of people's online models for time-slip through slow motion and other video intelligence. You can also use the libraries we create effects by packing with the camera.

If you're interested in trouble, you should realize that the module has a five-megapixel fixed-center camera that supports stills 1080p30, 720p60 and VGA90 video modes. It connects to the CSI port on the Raspberry Pi via a 15 cm lace link.

The camera works with all models of the Raspberry Pi 1 and 2. This can be achieved very well through the MMAL and V4L APIs, and various external libraries are working, including the on-camera Python library. The Camera Module is well known in Home Security Applications and the Natural Life Camera Trap.

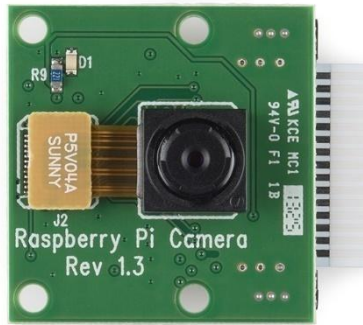

Figure 5: Raspberry pi camera module

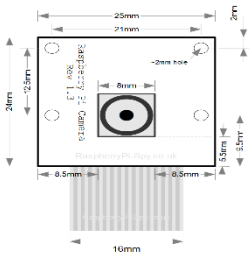

Figure 6: Raspberry pi camera module Dimensions

Circuit

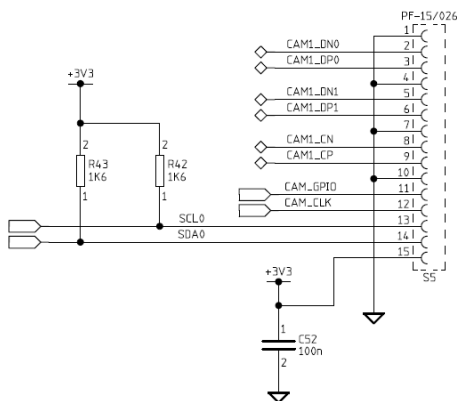

Figure 7: Raspberry pi with camera module circuit

II. MATHEMATICAL MODELLING

The fabrication of the smart bin involves various calculations and design. It involves the selection of proper pneumatic cylinder with following specifications that meets to crush the bottle.

Mechanical parameters considered

- Length of the can
- Maximum force required to crush a average plastic bottle/tin can

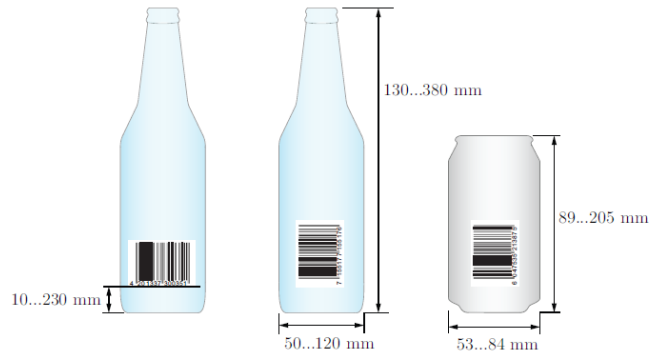

Figure 8 Can and bottle.

Force required to crush the can= 281 N

[From “Design and Fabrication of Can crusher paper in International Journal of Innovative research in science and technology.]

Can specifications

Height = 18 cm

Diameter = 5.4 cm

Weight = 0.54 kg

Bottle length = 18 cm

Stroke length of the Double acting cylinder = 16 cm (160 mm)

Specifications of double acting cylinder

Diameter of the cylinder = 32 mm

Diameter of the piston = 17 mm

Operating pressure range = 1-9 bar

Endurance pressure = 10 bar

Force = Pressure × Area

Area of the cylinder

$$A = \pi/4 \times \text{Diameter}^2$$

$$= \pi/4 \times 32^2$$

$$= 804.24 \text{ mm}^2$$

$$= 804.24 \times (10^{-3})^2$$

$$= 0.804 \times 10^{-3} \text{ m}^2$$

Force during expansion stroke

$$\text{Pressure} = \text{Force} / \text{Area}$$

$$P = F / A$$

$$A = \text{Area of cylinder}$$

Substituting values

$$6.5 \times 10^5 = \text{Force} / (0.804 \times 10^{-3})$$

$$\text{Force} = 522.6 \text{ N}$$

Area of the piston

$$a = \pi/4 \times \text{Diameter}^2$$

$$= \pi/4 \times 10^2$$

$$= 78.53 \text{ mm}^2$$

$$= 78.53 \times (10^{-3})^2$$

$$= 7.853 \times 10^{-5} \text{ m}^2$$

Force during retraction stroke

$$\text{Pressure} = \text{Force} / (A-a)$$

$$A = \text{Area of cylinder}$$

$$a = \text{Area of the piston}$$

Substituting values

$$1 \times 10^5 = \text{Force} / \{(0.804 \times 10^{-3}) - (7.853 \times 10^{-5})\}$$

$$7.2547 \times 10^{-4} \times 1 \times 10^5 = \text{Force}$$

$$\text{Force} = 72.547 \text{ N}$$

Air consumption during forward stroke

$$A1 = (\pi/4 \times \text{Diameter}^2 \times \text{Stroke length})$$

$$= (\pi/4 \times D^2 \times l)$$

$$= (\pi/4 \times (32 \times 10^{-3})^2 \times 0.16)$$

$$\text{Air consumption} = 1.287 \times 10^{-4} \text{ m}^3$$

$$= 1.287 \times 10^{-4} \times 10^3 \text{ liters}$$

$$= 0.12 \text{ liters}$$

Air consumption during return stroke

$$A2 = (\pi/4 \times (\text{Diameter}^2 - \text{diameter}^2) \times \text{Stroke length})$$

$$= (\pi/4 \times (D^2 - d^2) \times l)$$

$$= (\pi/4 \times \{(32 \times 10^{-3})^2 - (17 \times 10^{-3})^2\} \times 0.16)$$

$$\text{Air consumption} = 0.923 \times 10^{-4} \text{ m}^3$$

$$= 0.923 \times 10^{-4} \times 10^3 \text{ liters}$$

$$= 0.0923 \text{ liters}$$

Consumption per cycle

Consumption per cycle = Air consumption during forward stroke + Air

Consumption during return stroke

$$\text{Consumption} = 0.12 + 0.0923$$

$$= 0.212 \text{ liters}$$

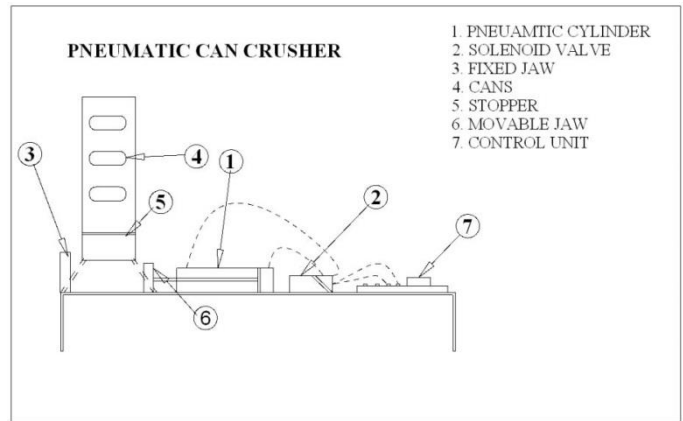

Figure 9 2D Model Diagram

IV. HARDWARE IMPLEMENTATION

The frames were welded using Arc welding. A coherent current electric welding supply generates electrical energy, which is directed at the arc by a section of exceptional ionized gas and metallic smoke called plasma. Further, the hopper portion was cut and welded. Then the guide ways for the runner were milled from mild steel, for the smooth flow of the cans to slide. Next the slotter of stainless steel material was cut to dimensions and grinded to smoothness. Finally, the mechanical and electronic parts were fitted together. For fixing the infrared sensor, a plated provision was welded to the vegetable cutter's setup. Motor was coupled to the pulley and worm gear was connected to the relays. Finally, the programming was done to the microcontroller using their compiler.



Figure 10 Photograph of the experimental setup

V. RESULTS

Results are obtained based on the output obtained from the smart bin. Plastic cans of 1 litre capacity are compressed using the smart bin and the

compressed volume is measured at the output. The obtained output is then compared with the volume of original volume and the ratio of compression is then calculated. The results suggest that the volume is reduced to one third of the original volume at the output. The result is shown in the TABLE 1 shown below.

TABLE 1: Comparison of Output and Input in Smart Bin

Sl. No	No of 1 litre cans	Volume in m3	Compressed volume in m3	Compression ratio
1.	100	0.1	0.028	0.28
2.	150	0.15	0.046	0.307
3.	200	0.2	0.067	0.335
4.	300	0.3	0.087	0.29
5.	450	0.45	0.152	0.338
6.	600	0.6	0.233	0.388

VI. CONCLUSIONS

A solid multidiscipline group with a good engineering base is fundamental for the Development and refinement of cutting edge PC programming, altering systems, symptomatic Software, calculations for the dynamic trade of instructive various degrees of chain of importance.

This project work gave us magnificent opportunity and experience so that our restricted information could be used. In addition to handling the work of this project, we have added a ton of information regarding handling, acquiring, collecting and matching.

We are pleased that we have finished the work with the constrained time effectively. "The fabrication of smart trash can" is working with palatable conditions. We can understand how to solve problems and maintain more quality. By using more systems, we can adjust and build them through applications.

REFERENCES

[1] SurveQais, SayedSaif, SayedJafar, ShaikhNadeem, "Fully Automatic Can

crusher" , International Journal of Mechanical and Industrial Technology, ISSN 2348-7593 (Online) Vol. 2, Issue 2, pp: (155-159), Month: October 2014 - March 2015

[2] R. Rajesh et al., Design and Fabrication of can crusher, IJRSET, VOL.5, Issue8, May 2016

[3] KunalSontakke et.al, Design and Fabrication of Automatic Can Crusher, IJIR, Vol. 2, Issue 7, 2016

[4] Mr.RamkrishnaS.More, Sunil J.Rajpal "Study of crusher". International Journal of Modern Engineering Research. (149): 91-100, 2014.

[5] AmanBhavisvak et al, Automatic Can Crusher, Ganpat University, 2012

[6] Mr. Patel RonakA, "Slider Crank Mechanism for four bar linkage". IJSRD - International Journal for Scientific Research & Development|, 2003.

[7] Michiko Amano, "PET Bottle System in Sweden and Japan: an Integrated Analysis from a Life-Cycle Perspective" proceedings of Masters' Thesis for LUMES - Lund University. pp. 2683-2688, 2012.

[8] "Design and Fabrication of Can crusher" paper in International Journal of Innovative research in science and technology 5th International Conference, 2007.

[9] Design Data Book for Machine Elements and Textbook of Machine Design by R.S.Khurmi and J.K.Gupta 14th edition S.Chnad Publication.

[10] Vishal Khirsagaret. al, An Automatic Approach for Can/ Plastic BottolCrushurMachine, IJRAME, Vol. 2, Issue 7, July 2014.

[11] Ch. Johnjoshuaet. al, Motorised Breverage Can Crusher, IJMETMR, Vol. 3, Issue 7, July 2016.