

To Mitigate Dispersion Effects in Coherent Optical WDM System Using DSP

^[1]Sunil Kumar Dahiya Name, ^[2]Amit Kumar Garg

^[1]Ph. D. Research scholar, Department of Electronics and Communication Engineering, DCRUST, Murthal, Sonapat, Haryana, India.

^[2]Professor, Department of Electronics and Communication Engineering, DCRUST, Murthal, Sonapat, Haryana, India.

Article Info

Volume 82

Page Number: 12633 - 12639

Publication Issue:

January-February 2020

Abstract:

Dispersion and attenuation of light signal are main hindrance in WDM optical communication system. Dispersion is spreading of pulse (wavelengths) without losing its original shape. This may cause of overlapping of pulses at output of fiber. Attenuation of signal can be overcome by using optical amplifier and dispersion can be compensated by using dispersion compensation fiber, fiber Bragg grating and optical phase conjugation. The performance of system can be enhanced by implementation for efficient digital compensation techniques in Coherent WDM system. This paper is analyzing the effect of linear impairments with existing techniques and proposed a digital mitigation technique for dispersion and polarization mode dispersion (PMD) in optical coherent system while ignore the nonlinear effects of optical transmission channel. The result of proposed digital technique shows clear constellation diagram i.e. clear symbols and indicate the improvement in Q-factor at bit error rate (about 10^{-9}) with advanced polarization multiplexed quadrature phase shift keying (PMQPSK) modulation at bit rate 100Gb/s. In addition, it also increases the achievable distance up to 200kms with DSP technique. This presented work shows improvement in both distance and quality of signal at minimum BER. It may consider the optimal solution to equalize the chromatic dispersion and PMD for coherent optical system.

Article History

Article Received: 18 May 2019

Revised: 14 July 2019

Accepted: 22 December 2019

Publication: 24 February 2020

Keywords: Coherent detection, Digital Signal Processing, Dispersion, Wavelength Division Multiplex.

I. INTRODUCTION

Optical signal gets attenuated when it is propagating through the optical fiber. Optical fiber is lossy, dispersive and nonlinear in nature due its physical geometry i.e. not perfectly cylindrical. Single mode fiber supports two orthogonal polarizations. These two independent components can travel together in single fiber with slightly different velocities and results the spreading of pulse. This spreading is referred as differential group delay (DGD). The value of DGD is less than about 24 nsec (nano second). Chromatic dispersion (CD) is the main source of pulse spreading. CD can compensate by using dispersion compensation fiber, dispersion shift fiber, fiber Bragg grating and optical phase compensation in optical fiber communication.

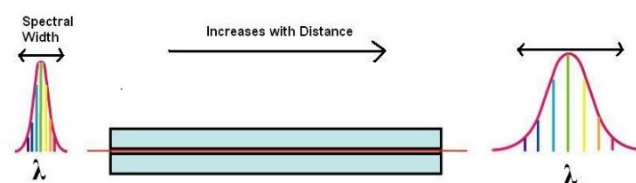

Fig. 1. Dispersion of Light signal.

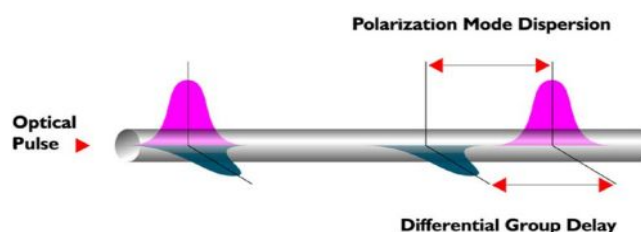

Fig. 2. Polarization Mode Dispersion.

Polarization Mode Dispersion of Light signal due to difference in velocity of two independent components of light.

Pre compensation, post -compensation and Symmetrical compensation are analyzed and symmetric compensation shows the best results to reduce dispersion among all three dispersion compensation techniques [1]. Analysis of DCF and FBG, the performance of DCF is better than FBG in term of Q-factor and BER at 100 Gb/s bit rate with single mode fiber of 120 Kms [2]. The symmetrical compensation method indicates the best performance in terms of improved Q-factor at minimum BER among the pre-, post- and symmetrical methods [3,4]. The implementation of Chirped FBG gives the better results as compare to DCF in dense WDM optical coherent communication system. The values of FBG length i.e. 15mm and 20mm) are more suitable for long distance. The chirped FBG is used to improve the performance [5]. 112Gb/s NRZPDM-QPSK optical coherent system simulated with different time domain adaptive filter and frequency domain equalizer and found that Least mean square filter has more tolerance to dispersion [6]. The results of WDM system with the dispersion compensation module like CDF and FBG, observed that Q-factor increases with channel spacing. Gain decreases with increases in length of optical fiber [7]. Optical phase conjugation has better performance than FBG and observed that when the frequency of transmitted signal increases then, dispersion decreases [8]. Analysis of WDM system with DCF (pre, post and symmetrical) compensation techniques using DCF at different fiber lengths and observed that symmetrical compensation has better performance than others. The acceptable value of BER (10^{-12}) and Q factor are obtained at optical fiber length above 320Kms with Return – to- zero (RZ) modulation format [11]. DSP techniques is useful to compensate the linear and nonlinear effects presents in coherent optical communication system [12].

In this paper, section II simulation of existing compensation techniques like DCF and FBG and their results. Section III simulation of PM-QPSK

with 10Gb/s at different input power levels, at different length of fiber span and varying the number of taps of DSP filter. Section III, the simulation results of proposed DSP technique in optical coherent communication system. The further sections consist results, conclusion and future scope of proposed work.

II. SIMULATION OF EXISTING DISPERSION COMPENSATION TECHNIQUES

Opti system software is used to observe the effect of dispersion on the performance of optical communication system. There are some existing techniques such as dispersion compensation fiber, fiber Bragg grating etc. Q-factor and BER are considered as performance metrics.

A. Dispersion compensation fiber

DCF is placed at three different positions such as pre, post and symmetrical.

Table I. Parameters Set-up

Parameter	Values	Unit
Bit rate	2.5e+009	bit/s
Time window	51.2e-009	s
Sample rate	160e+009	Hz
Sequence length	128	Bits
Samples per bit	64	
Symbol rate	10e+009	symbols/s
Number of samples	8192	
Reference wavelength	1550	nm
SMF	Span length	120Km
	Dispersion	16.75 ps/nm-km
	Dispersion slope	0.08 ps/nm ² -km
	Attenuation	0.2 dB/Km
	Core area	80 u m ²

DCF	Span length	24 Km
	Dispersion	-80 ps/nm-km
	Dispersion slope	0.21 ps/nm ² -km
	Attenuation	0.5 dB/Km
	Core area	30 u m ²

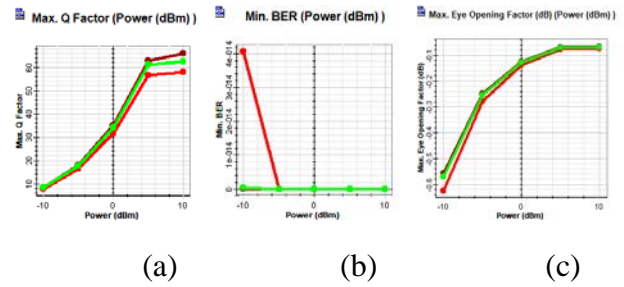

Fig. 4(a-c). Results of simulation for different placement of DCF a) Q-factor varies with power b) BER varies with power c) Eye opening varies with power.

(Pre- compensation --RED, Post- compensation -- BROWN and Symmetrical compensation—GREEN)

In fig. 4 (a-c) show that Post compensation technique gives the better results among three techniques i.e. high Q-factor, low BER and high eye-opening factor as input power level varies from -10dBm to 10dBm.

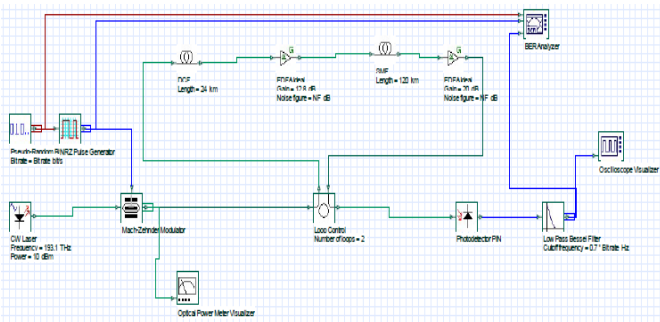

Fig. 3(a). Dispersion Pre compensation DCF

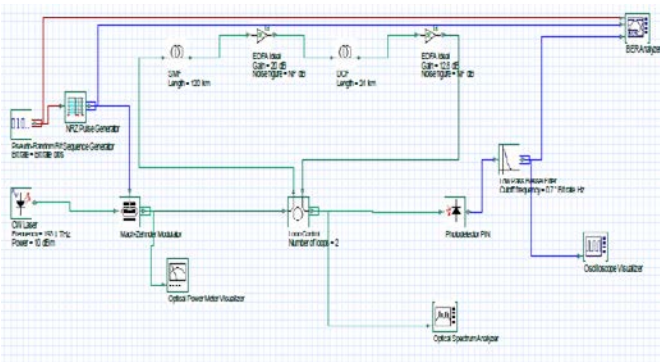

Fig. 3(b). Dispersion Post compensation DCF.

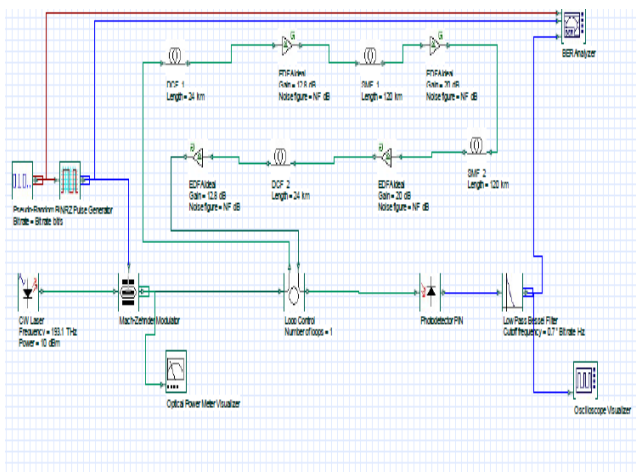

Fig. 3(c). Dispersion Symmetrical compensation DCF.

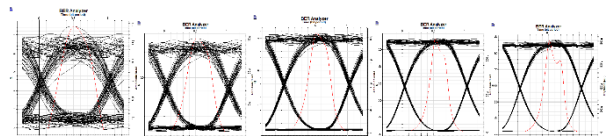

Fig.5a. Eye diagram(Pre-DCF) with varying power level (-10, -5, 0, 5 and 10dBm).

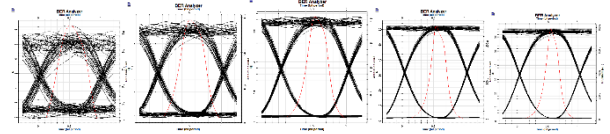

Fig. 5b. Eye diagram(Post-DCF) with varying power level (-10, -5, 0, 5 and 10dBm).

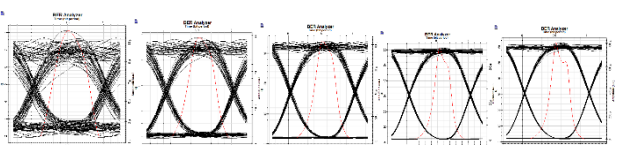

Fig. 5c. Eye diagram(Symmetrical-DCF) with varying power level (-10, -5, 0, 5 and 10dBm).

B. Fiber Bragg grating

FBG consists of periodic or aperiodic perturbation of refractive index in the core of single optical fiber.

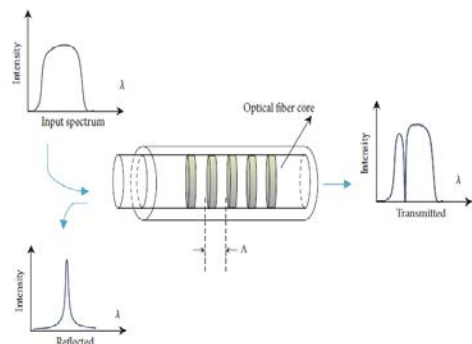

Fig. 6. Fiber Bragg grating [6].

Bragg grating wavelength λ_B in free space is given by

$$\lambda_B = 2 * \pi * n_{eff} * \Lambda \quad (1)$$

where as, n_{eff} : Effective refractive index; Λ : Grating spacing of FBG.

Table II. Set-up Parameters for FBG

FBG	Frequency	193.1 THz
	Length	7 mm

III. SET-UP FOR PROPOSED TECHNIQUE

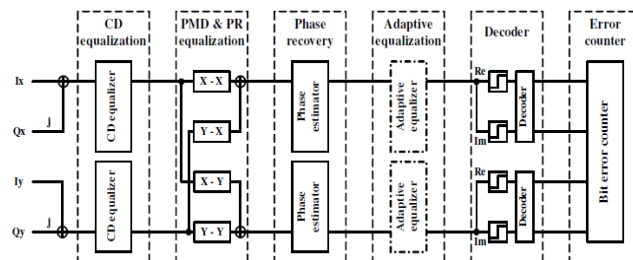

Fig. 9. Schematic of DSP based coherent receiver [6].

In fig. 9, DSP module consists of mainly five blocks. Firstly, FIR filters used for chromatic dispersion compensation, adaptive polarization mode dispersion and polarization rotation equalization, LMS filter used for phase noise compensation at CPE (carrier phase estimation) stage and residual dispersion equalize at adaptive equalization stage.

In fig 10, the setup of simulation scenario of PM-QPSK in Optisystem software such as data rate 10Gb/s, advanced PM-QPSK modulation format, 50*2 kms single mode fiber and DSP based coherent receiver etc. Coherent detection improves the sensitivity by 30dB. It is sensitive to frequency, phase and amplitude of signals. DSP module has capability to compensation or equalize with help of digital filters.

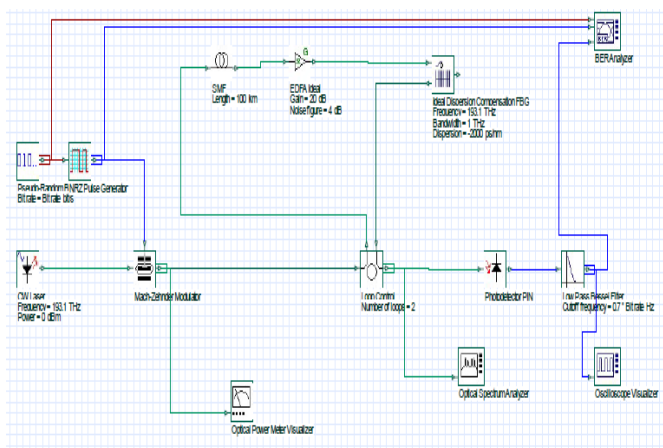

Fig. 7. Dispersion compensation with FBG.

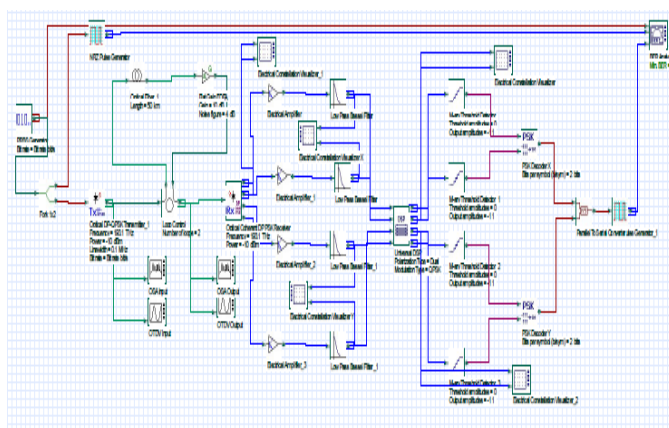

Fig.10. Simulation scenario of PM-QPSK with 10Gb/s DSP based coherent optical system (Length of fiber=50*2).

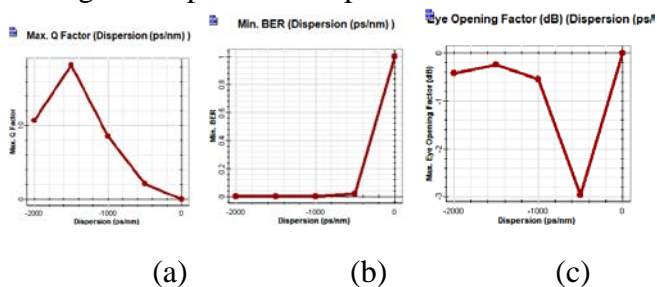

Fig. 8. Varying number of Taps Adaptive equalizer in DSP module a) Q-factor b) BER c) Eye opening.

IV. RESULTS AND DISCUSSION

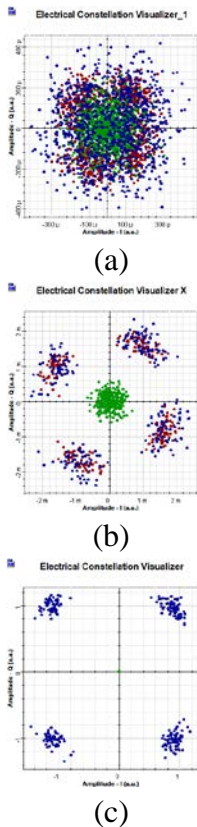

Fig. 11(a-c). Constellation diagrams the signal a) after coherent receiver b) after electrical filter c) after DSP module.

In fig. 11(a-c), the results show the clear images of symbols in Constellation diagrams after applying DSP filter.

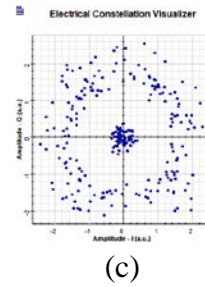
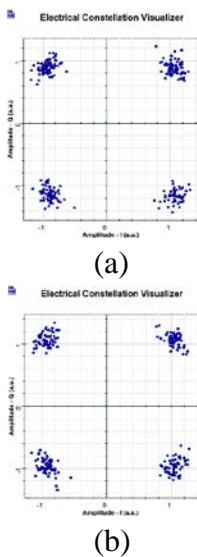

Fig. 12(a-c). Constellation diagram at number of tap a) 7 b)8 c) 9

In fig. 12(a-c), show that better constellation diagram at 8 number of taps of adaptive filter.

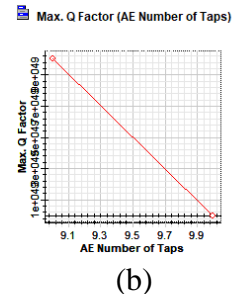
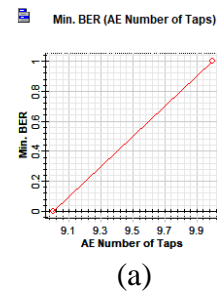
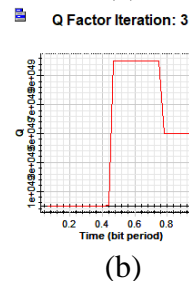
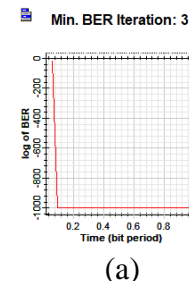
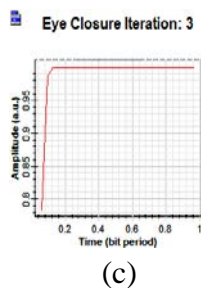

Fig. 13(a-b). Varying adaptive filter tap (8,9 and 10) with span $50 \times 2 = 100$ kms, BER increases with increase the no. of taps and Q-factor decreases with increases the numbers of taps of filter.





(c)

Fig. 14(a-c). Adaptive equalizer (No. of Taps=13) in DSP module a) Q-factor b) BER c) Eye opening.

In fig. 14(a-c), the results indicate the values of BER decreases, Q-factor increases with 13 numbers of taps for adaptive equalizer.

In fig.15, the setup of simulation scenario of PM-QPSK in Optisystem software such as high data rate 100Gb/s, advanced PM-QPSK modulation format, 100*2 kms single mode fiber and DSP based optical coherent receiver etc.

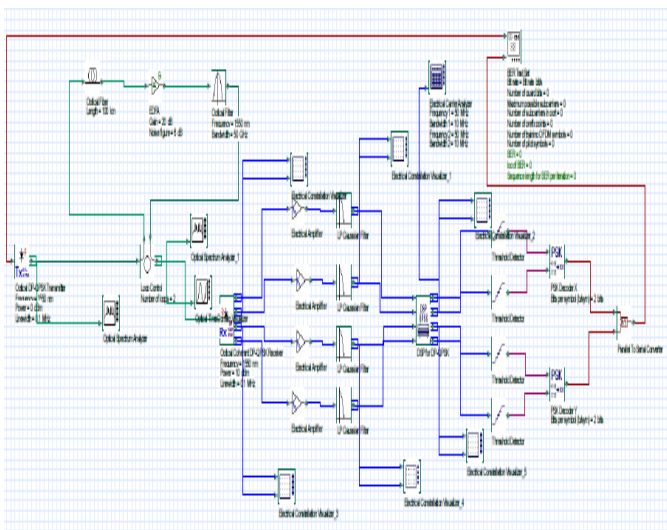
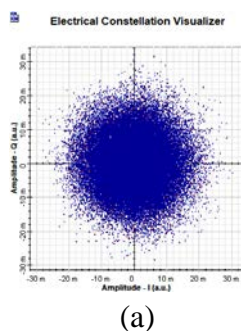
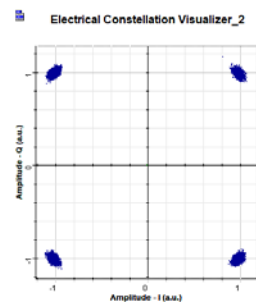

Fig. 15. Simulation scenario of PM-QPSK with 100Gb/s DSP based coherent optical system (Length of fiber=100*2).

We are simulating the DSP based coherent optical system with 100Gb/s.



(a)



(b)

Fig.16(a-b) Constellation diagram before (a) and after(b) DSP module.

CONCLUSION

It is observed that post- DCF compensation has performed better than among pre- and symmetrical-compensation configuration for dispersion. The results of post- FBG compensation are comparative better than post- DCF. The results of proposed DSP technique after simulation shows that Q-factor decreases and BER increases with increasing the number of taps of adaptive equalizer. The results with high data rate with DSP block, found that constellation diagram has clear symbols with 13 numbers of taps of adaptive equalizer. It indicates that improve in the Q-factor and also increase the achievable transmission distance up to 200kms. DSP techniques definitely improve the performance in terms of Q-factor, constellation diagram and transmission distance at minimum BER. The future scope of this work, it will be implemented to mitigate the nonlinear issues present in optical transmission.

REFERENCES

1. Sessa Sai Srikar S. and Subhashini N., "Analysis of Dispersion Compensation Methods in WDM Systems. Optical and Microwave Technologies," Optical and Microwave Technologies, Lecture Notes in Electrical Engineering, vol. 468, pp. 269-278, Springer, Singapore, 2018.
2. Sharma A., Singh I., Bhattacharya S. and Sharma S., "Performance Comparison of DCF and FBG as Dispersion Compensation Techniques at 100 Gbps Over 120 km Using SMF," Nanoelectronics, Circuits and Communication Systems, Lecture Notes in Electrical Engineering, vol 511, pp.435-

- 449, Springer, Singapore, 2019.
3. Meena D., Meena M. L., "Design and Analysis of Novel Dispersion Compensating Model with Chirp Fiber Bragg Grating for Long-Haul Transmission System," *Optical and Wireless Technologies, Lecture Notes in Electrical Engineering* (2020), vol. 546, pp. 29-36, 2019. https://doi.org/10.1007/978-981-13-6159-3_4.
 4. Kaler RS, Sharma AK and Kamal TS, "Comparison of pre-, post- and symmetrical-dispersion compensation schemes for 10 Gb/s NRZ links using standard and dispersion compensated fibers," *Optics Communications*, vol. 209, no. 1-3, pp. 107–123, 2002.
 5. Fahd C, Anas H, Mounia C and Mounir Y, "Chirped Bragg grating dispersion compensation in dense wavelength division multiplexing optical long-haul network," *International Journal of Microwave and Optical Technology*, vol. 10, no. 5, pp. 363-370, 2015.
 6. Tianhua Xu et al., "Chromatic Dispersion Compensation in Coherent Transmission System using Digital Filters," *Optics Express*, vol. 18, No. 15, pp. 16243-16257, 2010.
 7. Mounia Chakkour, Otman Aghzout, Badiia Ait Ahmed, Fahd Chaoui and Mounir Yakhouloufi, "Chromatic Dispersion Compensation Effect Performance Enhancements using FBG and EDFA-Wavelength Division Multiplexing Optical Transmission System," *Hindawi, International Journal of Optics*, 2017. <https://doi.org/10.1155/2017/6428972>
 8. Kishore Bhowmik, Md. Maruf Ahamed and Md. Abdul Momin, "Reduction of Dispersion in Optical Fiber Communication by Fiber Bragg Grating and Optical Phase Conjugation Techniques," *International Journal of Mobile Network Communications & Telematics*, vol.2, no.3, 2012.
 9. www.optiwave.com.
 10. Agarwal, G P, "Fiber –Optics Communication systems", A Johan –Wiley & sons, Inc. Publication, 3rd edition.
 11. Neheeda P, Pradeep M, Shaija P J, "Analysis of WDM System with Dispersion Compensation Schemes," 6th International Conference on Advances in Computing & Communications 2016, Cochin, India, 2016.
 12. Jian Zhao, Yaping Liu, Tianhua Xu, "Advanced

DSP for Coherent Optical Fiber Communication," *Applied sciences*, vol. 9, no. 19, 2019. <https://doi.org/10.3390/app9194192>