

Smart Bus Alert System for Easy Navigation of Blind

Dr. I. Lakshmi, Assistant Professor, Department of Computer Science, Stella Maris college, Chennai, Tamil Nadu, India

Article Info

Volume 82

Page Number: 12574 - 12580

Publication Issue:

January-February 2020

Article History

Article Received: 18 May 2019

Revised: 14 July 2019

Accepted: 22 December 2019

Publication: 24 February 2020

Abstract:

There are many techniques which are used for navigating the visually challenged people, navigation in real time traffic is the main problem. Objective of the project is to provide a solution with the aid of wireless sensor networks (WSNs). ZigBee system is used for indicating the presence of blind person in the bus station. Voice module and APR9600 audio playback systems are used to update and inform the blind person about the bus arriving and reaching destinations and to guide him as to what he has to do next. Microcontroller analysis the information provided and generates the corresponding bus number. ZigBee transceiver sends the bus number and announced in the microphone attached with the system. The system is connected with GPS which indicates the destination given. Audio output is generated by the voice synthesizer. The expected outcome of the project is to obtain an easy navigation system for people with visually impaired.

Keywords: APR9600, ARM7, GPS, Voice module, ZigBee.

I. INTRODUCTION

Society works essentially through the smooth trade of merchandise, administrations, and brotherhood. Be that as it may, data and assets are made most promptly accessible to the eye. The societal framework and trade system are intended to streamline the opportunity, working, and delight in located individuals - confronting the visually impaired with rejection from this system. The world is loaded with risks and ponders which society accepts the utilization of vision to maintain a strategic distance from or appreciate. Being visually impaired limits their exposures to these marvels and expands their risk to the perils. More undermining than being cut off from business and societal trade is the contrary condition of general world awareness in regards to visually impaired individuals. Mainstream thinking has dependably fought that visual deficiency drives specifically to lack and insufficiency. Our point is to add to making their lives ordinary in the little way that we can. As indicated by the measurements and predicts of the WHO upgraded in 2014, 285 million individuals are assessed to be outwardly disabled around the world:

39 million are visually impaired and 246 have low vision. Each outwardly impeded individual countenances diverse difficulties taking into account their particular level of vision. With the ascent of different backing based associations, all the more outwardly disabled individuals have been given the chance to instruction and numerous different means. However the issues of route for the visually impaired are still exceptionally mind boggling and troublesome particularly when they strolled down in road furthermore explore to inaccessible spots by open transport framework. Blind people might be unwilling to move openly and easily or, out of anxiety, society limits development of the visually impaired person. Deliberate, self-coordinated development is viewed as one of the all the more difficult ranges confronted by visually impaired individuals. While absence of sight is regularly remunerated by improving different faculties, social boundaries and systems of over insurance frequently hamper the perceptual advancement and improvement of useful development in visually impaired individuals. Guide puppies and strolling sticks take into

consideration a free method for navigation, however they are restricted in new situations. RFID is doable and financially savvy however it is more appropriate for indoor correspondence as it were. Likewise it gives stand out way correspondence and a short range

of identification. For open air correspondence, all the blind people trust that the guide route offices can manage them like an ordinary individual, and ensure that they are constantly advantageous and safe out and about. The motivation behind this project is to reduce the troubles confronted by blind person when taking city transports, using interactive wireless communication system.

II. MOTIVATION

To use technology for the welfare of the society which includes visually challenged people. The project outcome is indirectly related to the —Digital India concept which is introduced by Govt. of India. Smart city concept is also in its development stage which aims to bring about change in public transportation system. Thus the project is present day concept and hence supports innovation of the current/existing system.

III. EXISTING SYSTEM

Consider the case of blind how he confronts the accompanying issues, when utilizing open transport. Trip arranging – finding a stop/station - finding a passageway to the station - exploring inside the station - finding the right stage and holding up spot – knowing when the right vehicle arrives - finding a vehicle passageway - instalment - finding a seat – withdraw on right stop - exploring inside the station - finding the way out of the station - finding the destination The vast majority of these assignments are paltry for the located, yet exceptionally troublesome for the outwardly debilitated. There are situations when a visually impaired individual has spent a few hours on the transport stop, since he couldn't perceive entry of the right vehicle. What's more, present framework has taking after disadvantages.

- Manual operation
- Monitoring relies upon driver
- Alertness of the system is less
- System is unsafe

IV. PROBLEM STATEMENT

With expansion in movement and populace of the city areas the blind people confront a great deal of obstacles while venturing out starting with one point then onto the next. Because of this most of the blind people are compelled to stay inside and abandon their objectives and dreams as it might include driving from one spot to different spots and in this way costing them their profession/future. This anticipate archives the configuration and usage of a safe visually impaired route framework for the blind people to help them in going from their present area to their craved destination.

V. PROPOSED SYSTEM

To conquer the drawbacks of available accessible assistive gadgets, we propose a Wireless sensor system framework with ZigBee for blind identification in the bus station and installed framework for giving the bus information, lastly GPS for destination sign.

Proposed system has following features.

- ❖ Safety concerns for blinds
- ❖ Automatic operation
- ❖ Continuously quick monitor
- ❖ High alert system.

VI. SCOPE OF THE PROPOSED SYSTEM

- Blind can undoubtedly get the data about the transport to achieve destination, so travelling makes simple to him.
- Can travel autonomous of any persons need.
- User – friendly interactions with the user.
- Easy to use.
- Audio and vibration alert.
- Voice based input for destination target.
- This is not limited to just visually impaired individual it likewise helps senior individual.

- Communication is given between the visually impaired and driver if there should be an occurrence of any crisis.

VII. BLOCK DIAGRAM

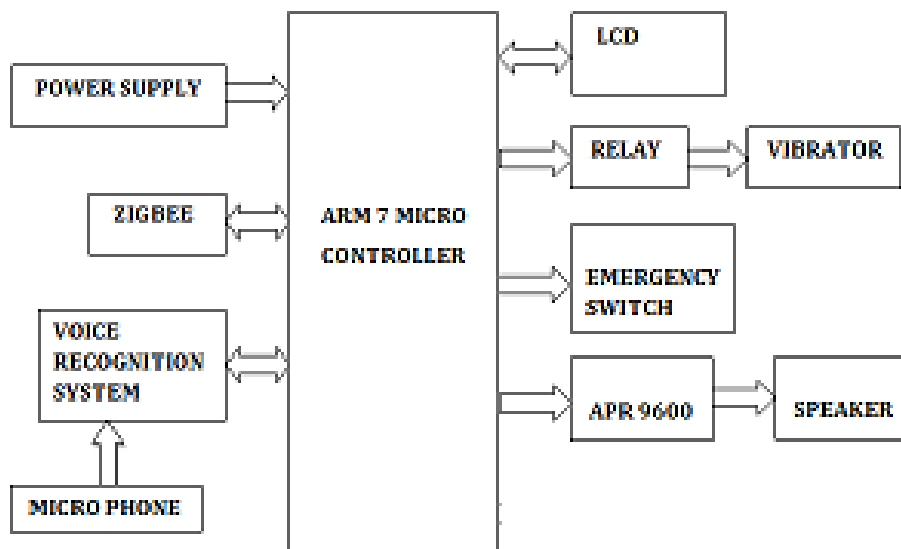

Fig 1: Blind unit.

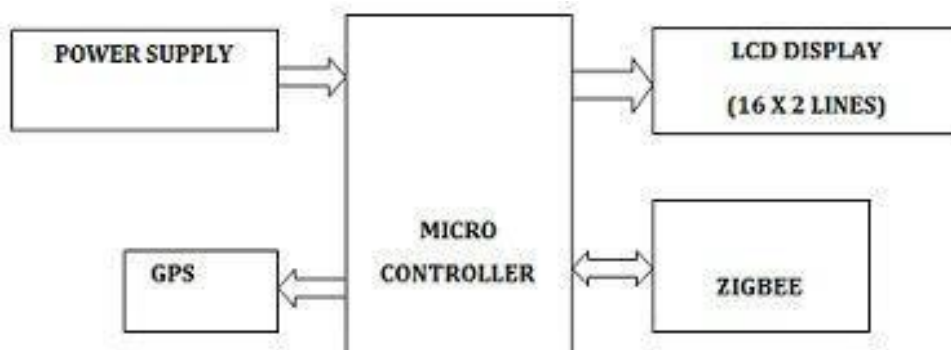

Fig 2: Bus unit.

VIII. WORKING DESCRIPTION

Stage 1: Acquisition of bus arrival information

The ZigBee in the blind module receives the signal which is transmitted by the ZigBee in the bus module within the 30 meters range. So that the blind person can easily get the information about bus arrival.

Stage 2: Intake of the destination to be travelled by the blind person

The blind person gives an audio input of the destination he wishes to reach to the system.

Stage 3: Reception of information by the bus

The blind person gives the input about destination to the voice module V2 and voice module translates the

voice of blind person to text and sends it to microcontroller.

Stage 4: Processing of bus information

Once the got signal changed over to text, it should be matched with the destination database present on the bus module so that the framework can illuminate the blind person if that bus is heading off to his wanted destination and in the event that he ought to take that specific bus or wait for the next one.

Stage 5: Audio output for blind interaction

Once the got signal has been decoded, the information is utilized to encourage the sound interface. A voice playback module is interfaced for redesigning the individual about different informations, for example, getting on and off the transport. In this anticipate GPS

is utilized for the visually impaired individual to understand that his stop has arrived. At the point when the transport contacts the visually impaired

individual's wanted destination he is again educated by his module that he ought to get off the transport.

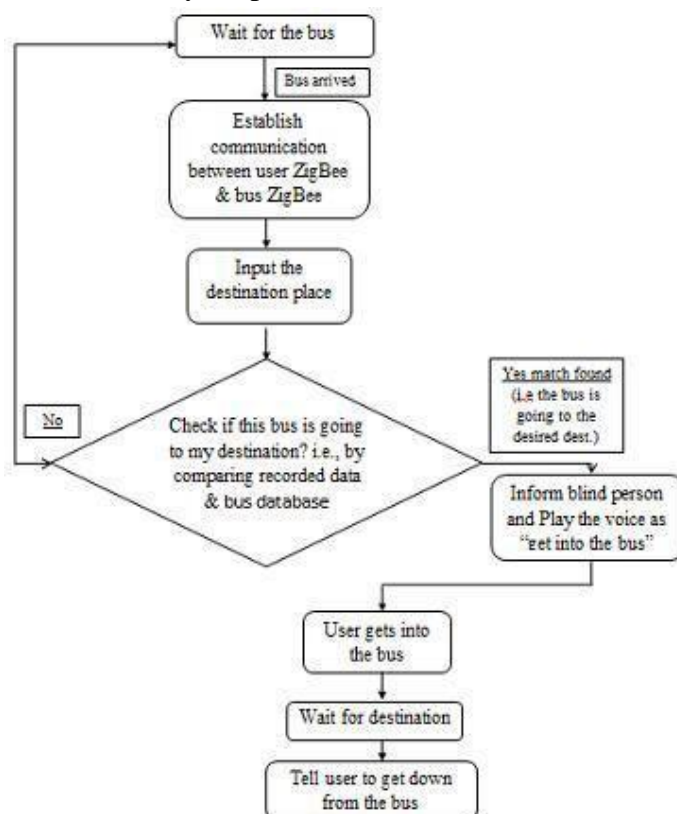

Fig 3: Flow chart

The above figure demonstrates stream flow chart. At the point when the blind module is turned ON, the ARM7 controller is initialized. The system waits for the ZigBee to establish the communication. The APR9600 plays that the bus has arrived loudly and also vibration alert for the blind upon the reception of the signal from the ZigBee on bus module. Now the

system waits for the blind to give the destination as voice input. All of the above processes are displayed on the LCD Once the bus module is turned ON it gets initialized and if it is in range of the user module ZigBee then it establishes connection and receives the data that is input from the blind person and the 8051 compares it with the database present on it. It sends back acknowledgement back to the user whether the bus goes to the destination or not.

IX. SYSTEM DESIGN MODEL

A. SOFTWARE DESIGNING:

The modules are required to be programmed for the operation. In this is project, Embedded C programming language is used by utilizing KEIL μ vision software. This is popular software that helps in creating embedded C programs, source code editing and debugging, compiling, execution can be done in one single environment. Developed program is dumped into the microcontroller memory by the programmer by the help of Flash Magic software.

B. HARDWARE DESIGN MODULE

Every single operation ought to be controlled. For the control activities, microcontrollers are utilized. ARM7 and 8051 controller are used in the blind and bus module respectively. ARM Board-LPC214X is a breakout board for LPC2148, ARM7TMDI based microcontroller. The LPC2148 microcontrollers depend on a 32-bit ARM7TDMI-S CPU with embedded trace support and real time emulation,

which join the microcontroller with installed flash memory. Since the bus module does not require a 32-bit controller as it doesn't have the more number of functions as the blind module, 8051 uC is utilized rather than another arm7 to spare expense without trading off on the usefulness. The Intel 8051 is a 8-bit microcontroller which implies that most accessible operations are constrained to 8 bits. There are 3 essential "sizes" of the 8051: Short, Standard, and Extended. The Short and Standard chips are regularly accessible in DIP (double in-line bundle) structure, yet the Extended 8051 models frequently have an alternate structure figure, and are not "drop-in perfect". To have the communication between the both modules, ZigBees are utilized. ZigBee gives remote RF correspondence. It Works on IEEE 802.15.4 standard and has low power utilization and has a scope of 30 meters which is appropriate for this application. The destination is given as contribution to the arm7 controller through voice module. There are different voice modules accessible like V1, V2, V3. Contrasted with V1, V2 is easy to control. But just serial information or yield of V1, V2 has other helpful approaches to control and yield the outcome. APR9600 is a sound recorder IC with playback limit for 60 seconds. It is utilized as a part of this anticipate to overhaul and advise the blind person about the bus arriving and achieving destinations and to guide him with reference to what he needs to do next. Vibrator is a small brushless DC motor and it is utilized as a part of this anticipate to give vibration alarm. This is one of the undeniable advantages with cellular telephones, you can get warnings when the gadget is in your pocket without upsetting those around user. GPS permits recording or making areas from spots on the earth and helping user explore to and from those spots. Here it is used to recognize the destination. Global Positioning System (GPS) satellites telecast signals from space that GPS recipients, use to give three-dimensional area (scope, longitude, and elevation) in addition to exact time. GPS receivers gives solid situating, route, and timing administrations to overall users on a ceaseless premise in all climate, day and night,

anyplace on or close to the Earth. GPS receivers can secure GPS signals from 65 stations of satellites and yield position information with high exactness in to a great degree testing situations and under poor sign conditions because of its dynamic antenna and high sensitivity. LCD is utilized here to show the operations which are occurring. A LCD is a little minimal effort show. It is easy to interface with a microcontroller due to an installed controller (the dark blob on the back of the board). This controller is standard crosswise over numerous presentations (HD 44780) which implies numerous microcontrollers (counting the Arduino) have libraries that make showing messages as simple as a solitary line of code. Thus it is essential gadget in inserted framework. It offers high adaptability to user as he can show the required information on it.

X. CONCLUSION

With this proposed scheme, a visually impaired person can successfully travel from his location to his desired destination using a bus independently without any hassle.

XI. FUTURE SCOPE

This system can further be improved by using GSM to provide communication between blind and his/her relatives in case of any emergency about more realistic location of his arrival and destination.

XII. RESULTS

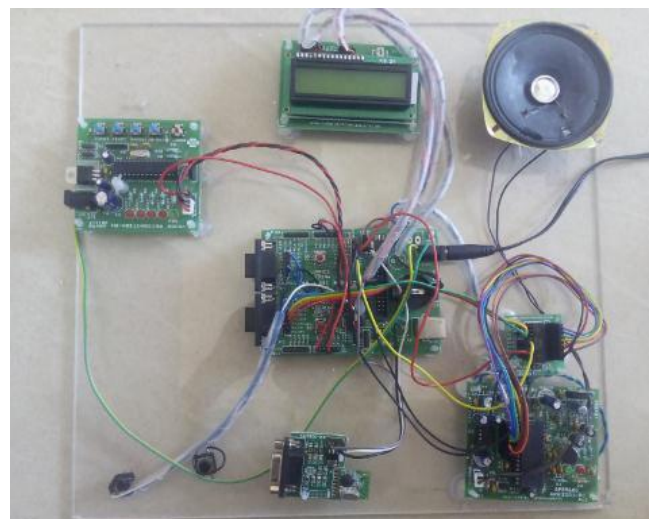

Fig 4: Blind module.

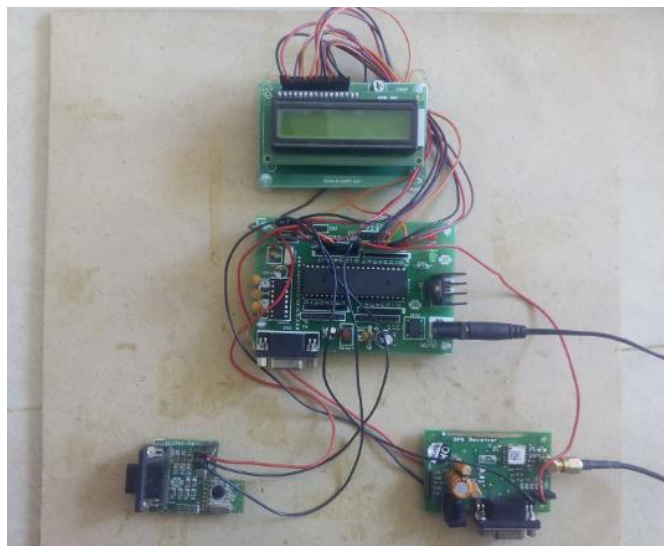

Fig 5: Bus module.

Images shown below are the experimental results.



REFERENCES

1. Olivier Venard, Geneviève Baudoin, Gérard Uzan, —Field Experimentation of the RAMPE Interactive Auditive Information System for the Mobility of Blind People in Public Transport : Final Evaluation| Intelligent Transport Systems Telecommunications,(ITST),2009 9th International Conference, Oct. 2009.
2. Syed Rizal Alfam Wan Alwi, Mohamad Noh Ahmad, —Survey on Outdoor Navigation System Needs for Blind People,| IEEE Student Conference on Research and Development (SCORED), 2013, pp.144-148.
3. Davor Virkes, Karmen Nenadic, Diana ZerecVirkes, —Positioning systems for mobility of the blind, overview and analysis,| 46th International Symposium Electronics in Marine, ELMAR- 2004, 16-18 June 2004.
4. Zadar, Croatia Passenger BUS Alert System for Easy Navigation of Blind, 2013 International Conference on Circuits, Power and Computing Technologies [ICCPCT-2013]
5. Mounir Bousbia-Salah, Abdelghani Redjati, Mohamed Fezari, MaamarBettayeb, —AN ULTRASONIC NAVIGATION SYSTEM FOR BLIND PEOPLE,| IEEE International Conference on Signal Processing and Communications (ICSPC 2007), pp.1003-1006.
6. Jin Liu, Jingbo Liu, Luqiang Xu, WeidongJin, —Silicon Eyes: GPS-GSM based Navigation Assistant for Visually Impaired using Capacitive Touch Braille Keypad and Smart SMS Facility, IEEE paper 2013.
7. Mohsin Murad, Abdullah Rehman, Arif Ali Shah, Salim Ullah, Muhammad Fahad, Khawaja M. Yahya, —RFAIDE – An RFID Based Navigation

and Object Recognition Assistant for Visually Impaired People, IEEE paper, 2011.

8. Adrien Brilhault, Slim Kammoun, Olivier Gutierrez, Philippe Truillet, Christophe Jouffrais, —Fusion of Artificial Vision and GPS to Improve Blind Pedestrian Positioning, IEEE paper, 2011.
9. Bin Ding, Haitao Yuan, Li Jiang, Xiaoning Zang, —The Research on Blind Navigation System Based on RFID.